



IEC 60913

Edition 3.0 2024-04  
COMMENTED VERSION

# INTERNATIONAL STANDARD



---

**Railway applications – Fixed installations – Electric traction overhead contact  
lines systems**

INTERNATIONAL  
ELECTROTECHNICAL  
COMMISSION

---

ICS 45.060.01

ISBN 978-2-8322-8740-8

**Warning! Make sure that you obtained this publication from an authorized distributor.**

## CONTENTS

FOREWORD .....	9
1 Scope .....	12
2 Normative references .....	12
3 Terms, definitions, symbols and abbreviated terms .....	16
3.1 Terms and definition .....	16
3.1.1 Systems .....	17
3.1.2 Conductors .....	21
3.1.3 Return circuit .....	22
3.1.4 Electrical .....	23
3.1.5 Geometrical .....	25
3.1.6 Structures .....	26
3.1.7 Foundations .....	27
3.1.8 Current collectors .....	28
3.1.9 Current collection .....	28
3.1.10 Testing .....	29
3.1.11 Miscellaneous .....	29
3.2 Symbols .....	29
3.3 Abbreviated terms .....	32
4 Fundamental design data .....	33
4.1 General .....	33
4.2 Line characteristics .....	33
4.3 Electrical power system design .....	33
4.4 Vehicle characteristics .....	34
4.5 Current collectors .....	34
4.6 Environmental conditions .....	35
4.7 Design life .....	35
5 System requirements .....	35
5.1 Design of electrical system .....	35
5.1.1 General .....	35
5.1.2 Temperature rise in conductors .....	35
5.1.3 Clearances between live parts of contact lines and earth .....	37
5.1.4 Clearances between adjacent live AC contact lines of differing voltage phases .....	40
5.2 Design of overhead contact line for current collection systems .....	40
5.2.1 General .....	40
5.2.2 Elasticity and its variation .....	41
5.2.3 Vertical movement of contact point .....	42
5.2.4 Calculated wave propagation velocity .....	42
5.2.5 Quality of current collection .....	43
5.2.6 Fatigue of contact wire .....	45
5.3 Mechanical design of contact wire loads .....	45
5.3.1 Permissible tensile stress $\sigma_w$ .....	45
5.3.2 Maximum temperature $K_{temp}$ .....	45
5.3.3 Allowable wear $K_{wear}$ .....	46
5.3.4 Wind <del>and ice</del> loads <del><math>K_{icewind}</math></del> $K_{wind}$ .....	46
5.3.5 Ice loads $K_{ice}$ .....	46

5.3.6	Efficiency of tensioning devices $K_{\text{eff}}$ .....	47
5.3.7	Termination fittings $K_{\text{clamp}}$ .....	47
5.3.8	Joints $K_{\text{joint}}$ .....	47
5.4	Mechanical design of catenary wire loads .....	47
5.4.1	Permissible tensile loading $F_{\text{w}}$ .....	47
5.4.2	Maximum temperature $K_{\text{temp}}$ .....	47
5.4.3	Wind loads $K_{\text{wind}}$ .....	48
5.4.4	Ice loads $K_{\text{ice}}$ .....	48
5.4.5	<del>Automatic tensioning accuracy and efficiency</del> $K_{\text{eff}}$ Efficiency and accuracy of tensioning device $K_{\text{eff}}$ .....	49
5.4.6	Termination fittings $K_{\text{clamp}}$ .....	49
5.4.7	Additional vertical load $K_{\text{load}}$ .....	49
5.5	Mechanical design of other stranded conductors .....	49
5.6	Mechanical design of solid wires .....	49
5.7	Mechanical design of ropes of non-conducting materials .....	49
5.7.1	General .....	49
5.7.2	Permissible tensile loading $F_{\text{w}}$ .....	49
5.7.3	Wind loads $K_{\text{wind}}$ .....	50
5.7.4	Ice loads $K_{\text{ice}}$ .....	50
5.7.5	Termination clamps $K_{\text{clamp}}$ .....	50
5.7.6	Vertical loads $K_{\text{load}}$ .....	50
5.7.7	Minimum bending radius $K_{\text{radius}}$ .....	50
5.8	Suspension systems .....	51
5.9	Tensioning <del>systems</del> device for flexible overhead contact lines .....	51
5.10	Geometry of overhead equipment .....	51
5.10.1	<del>Horizontal deflection</del> Lateral deviation of contact wire .....	51
5.10.2	Uplift .....	52
5.10.3	Variation in contact wire height .....	52
5.10.4	Contact wire height .....	53
5.10.5	Tolerances of lateral contact wire position .....	57
5.10.6	Span length .....	57
5.11	Contact line arrangement above turnouts and crossings .....	57
5.12	Overlap arrangements .....	58
5.13	Specific requirements for overhead contact lines for trolleybus systems .....	58
5.13.1	General .....	58
5.13.2	Line characteristics .....	59
5.13.3	Vehicle characteristics .....	60
5.13.4	Current collector system .....	60
5.13.5	Static contact forces .....	60
5.13.6	Trolleybus in the vicinity of tramways .....	60
5.14	Tolerances and limits .....	61
6	Structures and foundations .....	62
6.1	Basis of design .....	62
6.1.1	General .....	62
6.1.2	Basic requirements .....	62
6.1.3	Design with regard to structural limits .....	63

6.1.4	Classification of actions .....	63
6.1.5	Reliability levels .....	64
6.1.6	Models for structural analysis and resistance .....	64
6.1.7	Design values and verification methods.....	64
6.1.8	Wall anchors .....	66
6.2	Actions on overhead contact lines .....	66
6.2.1	General.....	66
6.2.2	Permanent loads .....	67
6.2.3	Variable loads .....	67
6.2.4	Wind loads .....	67
6.2.5	Ice loads .....	72
6.2.6	Combined wind and ice loads.....	73
6.2.7	Temperature effects .....	73
6.2.8	Construction and maintenance loads.....	73
6.2.9	Accidental loads .....	74
6.2.10	Special actions.....	74
6.3	Types of structures and related load cases.....	75
6.3.1	Load cases and load combinations.....	75
6.3.2	Type of structures and application of load cases.....	76
6.3.3	Partial factors for actions .....	79
6.4	Design of cross-span supports and structures.....	80
6.4.1	Analysis of internal forces and moments .....	80
6.4.2	Analysis of resistance.....	81
6.4.3	Material partial factors .....	81
6.4.4	Verification of resistance .....	82
6.4.5	Verification of serviceability .....	82
6.4.6	Material for structures.....	83
6.4.7	Corrosion protection and finishes.....	84
6.5	Foundations .....	84
6.5.1	General.....	84
6.5.2	Design of foundations .....	84
6.5.3	Calculation of actions .....	85
6.5.4	Geotechnical design .....	85
6.5.5	Partial factors for foundations .....	88
6.5.6	Verification of stability .....	89
6.5.7	Calculation of displacements.....	89
6.5.8	Materials for foundations .....	90
6.5.9	Structural details .....	90
6.5.10	Protection against corrosion and weathering .....	90
6.5.11	Electrical design.....	91
6.5.12	Installation of foundations.....	91
7	Assembly and Component requirements .....	92
7.1	General.....	92
7.1.1	Design life.....	92
7.1.2	Component identification .....	92
7.1.3	Corrosion and erosion .....	92
7.2	Supporting assemblies.....	93
7.3	Contact wire .....	93
7.4	Other conductors and ropes.....	93

7.5	Tensioning devices .....	94
7.6	Mechanical midpoints .....	94
7.6.1	General.....	94
7.6.2	Catenary wire fixed points.....	94
7.6.3	Contact wire fixed points.....	94
7.7	Droppers .....	95
7.7.1	Mechanical requirements .....	95
7.7.2	Electrical requirements .....	95
7.8	Clamps and line fittings.....	95
7.8.1	Mechanical requirements .....	95
7.8.2	Electrical requirements .....	96
7.9	Electrical connectors .....	96
7.10	Insulators .....	96
7.10.1	General requirements .....	96
7.10.2	Mechanical requirements .....	97
7.10.3	Insulator surface.....	97
7.11	Sectioning devices.....	97
7.11.1	Definition.....	97
7.11.2	Mechanical requirements .....	97
7.11.3	Electrical requirements .....	98
7.12	Disconnectors and drives .....	98
7.13	Protection devices .....	99
7.13.1	Covers and obstacles .....	99
7.13.2	Surge protection and voltage limiting devices .....	99
7.14	Specific components for trolleybus systems.....	99
7.14.1	General.....	99
7.14.2	Turnouts and crossings.....	99
7.15	Automatic earthing and short-circuiting equipment.....	100
7.16	Monitoring devices.....	100
8	Testing .....	100
8.1	Testing of components and assemblies – General .....	100
8.2	Support assemblies .....	101
8.2.1	Type test.....	101
8.2.2	<del>Random sample</del> Sampling test.....	110
8.2.3	Routine test.....	112
8.3	Contact wires .....	112
8.4	Other conductors .....	112
8.5	Tensioning devices .....	113
8.5.1	Tests required .....	113
8.5.2	Type tests for tensioning devices with balance weights.....	113
8.5.3	Type tests for tensioning device without balance weight .....	114
8.6	Mechanical midpoints .....	114
8.7	Droppers .....	114
8.7.1	Tests required .....	114
8.7.2	Mechanical fatigue test.....	115
8.7.3	Mechanical tests.....	118
8.8	Clamps, splices and other fittings.....	118
8.9	Electrical connectors .....	118
8.9.1	General.....	118

8.9.2	Mechanical fatigue tests .....	119
8.10	Insulators .....	119
8.11	Sectioning devices.....	120
8.11.1	Type test.....	120
8.11.2	Field test.....	121
8.11.3	Sampling tests.....	121
8.11.4	Routine tests.....	121
8.12	Disconnectors and drives.....	121
8.13	Surge protection and voltage limiting devices .....	122
8.14	Specific components for trolleybus systems.....	122
8.15	System test .....	122
8.15.1	Demonstration of conformity .....	122
8.15.2	Acceptance tests.....	123
8.15.3	Commissioning tests.....	123
9	Minimum documentation.....	124
9.1	General.....	124
9.2	System specification.....	124
9.3	Basic design.....	124
9.4	Installation design.....	124
9.5	Installation and maintenance.....	124
<del>Annex A (informative) Current-carrying capacity of conductors .....</del>		
Annex A (informative)	Structural details .....	126
Annex B (informative)	Information on wind load calculation.....	128
B.1	Peak velocity pressure calculation.....	128
B.2	Drag factors $C_{str}$ .....	129
Annex C (informative)	Recommendations for ultimate limit state (ULS) design .....	130
C.1	General.....	130
C.2	Material partial factors for structural calculations .....	130
C.3	Design limits for pre-stresses concrete poles.....	130
C.4	Partial factors for foundations .....	131
Annex D (informative)	Geotechnical soil investigation and soil characteristics .....	132
Annex E (informative)	Overhead contact line for electric vehicles with pantographs on electrified roads .....	135
E.1	General OCL properties and road characteristics.....	135
E.2	Electrical properties of the OCL .....	135
E.3	Capacity and service life of the OCL system .....	136
E.4	OCL properties .....	136
E.4.1	OCL mechanical properties, horizontal and vertical dimensions .....	136
E.4.2	Design of begin and end of OCLS .....	138
E.4.3	Uplift and dynamic properties of the OCL .....	139
E.5	Contact forces .....	139
E.6	ERS clearance requirements.....	140
E.6.1	General.....	140
E.6.2	Contact wire clamps .....	142
E.6.3	Miscellaneous structure gauges and clearance requirements .....	142
E.6.4	Structure gauge width – Lateral clearance requirements .....	143
E.6.5	Clearance under bridges or height-limiting structures.....	143

Annex F (informative) Information on uniformity of elasticity of OCL within a span length .....	144
Annex G (informative) Seismic actions for OCS poles on viaducts .....	145
Annex H (normative) Special national conditions .....	146
Bibliography.....	149
List of comments.....	156
Figure 1 – Scope of contact line systems .....	12
Figure 2 – Static electrical clearance in air between live parts of an insulator and earthed equipment .....	39
Figure 3 – Relationship between contact wire heights and pantograph operating position.....	56
Figure 4 – Position of return wire in relation to right-of-way .....	59
Figure 5 – Wind action on lattice steel structures .....	71
Figure 6 – Definition of drag factors for double channel- <del>structure</del> pole .....	72
Figure 7 – Description of dimensions and minimum conductor lengths .....	108
Figure 8 – Potential measuring points- <del>at a connecting clamp and a butt joining clamp</del> .....	109
Figure 9 – Potential measuring points at a T-type infeed terminal .....	110
Figure 10 – Example of a tensioning device measurement test .....	114
Figure 11 – Examples of a dropper test cycle .....	116
Figure 12 – Example of a dropper tension test assembly .....	118
Figure 13 – Example of a test cycle for an electrical connection.....	119
Figure E.1 – Overlap span (plan view, exemplary design for anchoring, representation without electrical connections).....	138
Figure E.2 – Defined points along the OCL (side view, idealized).....	138
Figure E.3 – Clearance gauge overview.....	140
Figure E.4 – Clearance gauge detail .....	141
Figure G.1 – Simulation method for evaluation for the safety of poles against earthquakes.....	145
Table 1 – Temperature limits for material mechanical properties.....	36
Table 2 – Typical electrical clearances.....	38
Table 3 – <del>Clearance between differing phases</del> Typical clearances between adjacent live AC contact line systems of differing voltage phase .....	40
Table 4 – Contact force limits .....	43
Table 5 – Factor $K_{temp}$ for contact wires .....	45
Table 6 – Factor $K_{wind}$ for contact wires.....	46
Table 7 – Factor $K_{ice}$ for contact wires .....	46
Table 8 – Factor $K_{temp}$ for stranded conductors .....	48
Table 9 – Factor $K_{wind}$ for stranded conductors.....	48
Table 10 – Factor $K_{ice}$ for stranded conductors.....	48
Table 11 – Factor $K_{radius}$ for ropes of non-conducting materials .....	50
Table 12 – Recommended maximum contact wire gradients for flexible contact lines.....	53
Table 13 – Important parameters to assist in the definition of tolerances and limits .....	61

<del>Table 13 – Recommended values for factor <math>C_{str}</math> for different structure types</del>	
Table 14 – Parameters for wind load calculation	69
Table 15 – <del>Summary of</del> Load cases to be considered for each type of structures	79
Table 16 – <del>Summary of</del> Partial factors for actions to be considered	80
<del>Table 16 – Recommended values for partial factors <math>\gamma_M</math> for steel material</del>	
<del>Table 17 – Recommended values for partial factors <math>\gamma_M</math> for concrete structures</del>	
<del>Table 18 – Recommended values for partial factors <math>\gamma_M</math> for foundations</del>	
Table 17 – Tightening torques $M_t$ for regularly used bolts	102
Table 18 – Examples of bolt connections	103
Table 19 – Assignment of the strength of bolt and nut	103
Table 20 – Conversion factor for tightening torques	104
Table 21 – Minimum conductor lengths	108
<del>Table A.1 – Continuous current-carrying capacity of conductors and contact wires</del>	
Table A.1 – Recommended dimensions of connections and edge distances of jointing components	126
Table B.1 – Recommended values for gust response factor $G_q$	128
Table B.2 – Recommended values for terrain factor $G_t$	128
Table B.3 – Recommended values for factor $C_{str}$ for different pole types	129
Table C.1 – Recommended values for partial factors $\gamma_M$ for steel structures	130
Table C.2 – Recommended values for partial factors $\gamma_M$ for concrete structures	130
Table C.3 – Recommended values for partial factors $\gamma_M$ for foundations	131
Table D.1 – Geotechnical characteristic parameters of some standard soils according to EN 50341-1:2001/2012, <del>Annex N for Europe</del> Table M.2	133
Table E.1 – Standard contact wire specifications	136
Table E.2 – Contact wire vertical position parameters, all values measured perpendicular to the idealized top of the road surface	137
Table E.3 – Contact wire horizontal position parameters	137
Table E.4 – Defined points along the OCL (side view)	139
Table E.5 – Contact forces pantograph – OCL	139
Table E.6 – Clearance gauge overview description	141
Table E.7 – Pantograph clearance definitions	142
Table F.1 – Uniformity $u$ of elasticity	144
Table H.1 – Typical tolerances of overhead contact line system	146



## INTERNATIONAL ELECTROTECHNICAL COMMISSION

**RAILWAY APPLICATIONS – FIXED INSTALLATIONS –  
ELECTRIC TRACTION OVERHEAD CONTACT LINE SYSTEMS**

## FOREWORD

- 1) The International Electrotechnical Commission (IEC) is a worldwide organization for standardization comprising all national electrotechnical committees (IEC National Committees). The object of IEC is to promote international co-operation on all questions concerning standardization in the electrical and electronic fields. To this end and in addition to other activities, IEC publishes International Standards, Technical Specifications, Technical Reports, Publicly Available Specifications (PAS) and Guides (hereafter referred to as “IEC Publication(s)”). Their preparation is entrusted to technical committees; any IEC National Committee interested in the subject dealt with may participate in this preparatory work. International, governmental and non-governmental organizations liaising with the IEC also participate in this preparation. IEC collaborates closely with the International Organization for Standardization (ISO) in accordance with conditions determined by agreement between the two organizations.
- 2) The formal decisions or agreements of IEC on technical matters express, as nearly as possible, an international consensus of opinion on the relevant subjects since each technical committee has representation from all interested IEC National Committees.
- 3) IEC Publications have the form of recommendations for international use and are accepted by IEC National Committees in that sense. While all reasonable efforts are made to ensure that the technical content of IEC Publications is accurate, IEC cannot be held responsible for the way in which they are used or for any misinterpretation by any end user.
- 4) In order to promote international uniformity, IEC National Committees undertake to apply IEC Publications transparently to the maximum extent possible in their national and regional publications. Any divergence between any IEC Publication and the corresponding national or regional publication shall be clearly indicated in the latter.
- 5) IEC itself does not provide any attestation of conformity. Independent certification bodies provide conformity assessment services and, in some areas, access to IEC marks of conformity. IEC is not responsible for any services carried out by independent certification bodies.
- 6) All users should ensure that they have the latest edition of this publication.
- 7) No liability shall attach to IEC or its directors, employees, servants or agents including individual experts and members of its technical committees and IEC National Committees for any personal injury, property damage or other damage of any nature whatsoever, whether direct or indirect, or for costs (including legal fees) and expenses arising out of the publication, use of, or reliance upon, this IEC Publication or any other IEC Publications.
- 8) Attention is drawn to the Normative references cited in this publication. Use of the referenced publications is indispensable for the correct application of this publication.
- 9) IEC draws attention to the possibility that the implementation of this document may involve the use of (a) patent(s). IEC takes no position concerning the evidence, validity or applicability of any claimed patent rights in respect thereof. As of the date of publication of this document, IEC had not received notice of (a) patent(s), which may be required to implement this document. However, implementers are cautioned that this may not represent the latest information, which may be obtained from the patent database available at <https://patents.iec.ch>. IEC shall not be held responsible for identifying any or all such patent rights.

**This commented version (CMV) of the official standard IEC 60913:2024 edition 3.0 allows the user to identify the changes made to the previous IEC 60913:2013 edition 2.0. Furthermore, comments from IEC TC 9 experts are provided to explain the reasons of the most relevant changes, or to clarify any part of the content.**

**A vertical bar appears in the margin wherever a change has been made. Additions are in green text, deletions are in strikethrough red text. Experts' comments are identified by a blue-background number. Mouse over a number to display a pop-up note with the comment.**

**This publication contains the CMV and the official standard. The full list of comments is available at the end of the CMV.**

IEC 60913 has been prepared by IEC technical committee 9: Electrical equipment and systems for railways. It is an International Standard.

This third edition cancels and replaces the second edition published in 2013. This edition constitutes a technical revision.

The European standard EN 50119 has served as a basis for the elaboration of this document.

This edition includes the following significant technical changes with respect to the previous edition:

- a) title modified;
- b) requirements for urban rail systems are included;
- c) requirements for rigid overhead contact line (ROCL) are included;
- d) additional definitions for new terms are included (Clause 3);
- e) clearances and geometry of overhead contact line are improved (Clause 5);
- f) urban aspects are added, for example wall anchors (Clause 6);
- g) requirements for monitoring devices, automatic earthing and short-circuiting equipment are included (Clause 7);
- h) requirements for overhead contact line for electric vehicles with pantograph on electrified roads are added (Annex E)
- i) improvements on the basis of EN 50119:2020 and the questionnaire 9/2619A/Q

The text of this International Standard is based on the following documents:

Draft	Report on voting
9/3031/FDIS	9/3052/RVD

Full information on the voting for its approval can be found in the report on voting indicated in the above table.

The language used for the development of this International Standard is English.

This document was drafted in accordance with ISO/IEC Directives, Part 2, and developed in accordance with ISO/IEC Directives, Part 1 and ISO/IEC Directives, IEC Supplement, available at [www.iec.ch/members\\_experts/refdocs](http://www.iec.ch/members_experts/refdocs). The main document types developed by IEC are described in greater detail at [www.iec.ch/publications](http://www.iec.ch/publications).

The reader's attention is drawn to the fact that Annex H lists all of the "in-some-country" clauses on differing practices of a less permanent nature relating to the subject of this document.

The committee has decided that the contents of this document will remain unchanged until the stability date indicated on the IEC website under [webstore.iec.ch](http://webstore.iec.ch) in the data related to the specific document. At this date, the document will be

- reconfirmed,
- withdrawn, or
- revised.

**IMPORTANT – The "colour inside" logo on the cover page of this document indicates that it contains colours which are considered to be useful for the correct understanding of its contents. Users should therefore print this document using a colour printer.**

# RAILWAY APPLICATIONS – FIXED INSTALLATIONS – ELECTRIC TRACTION OVERHEAD CONTACT LINE SYSTEMS

## 1 Scope

~~This International Standard applies to electric traction overhead contact line systems in heavy railways, light railways, trolley busses and industrial railways of public and private operators.~~

~~It applies to new installations of overhead contact line systems and for the complete reconstruction of existing overhead contact line systems.~~

This document specifies the requirements and tests for the design of overhead contact line systems, requirements for structures and their structural calculations and verifications as well as the requirements and tests for the design of assemblies and individual parts.

~~This standard does not provide requirements for conductor rail systems where the conductor rails are located adjacent to the running rails.~~

This document is applicable to electric traction overhead contact line systems in heavy railways, light railways, for trolley bus lines, electric road systems **1** (Annex E) and industrial railways of public and private operators. This document is applicable to new installations of overhead contact line systems and for the complete renewal of existing overhead contact line systems.

This document does not apply to ground level conductor rail systems (see Figure 1).

NOTE Ground level conductor rail means conductor rails located adjacent to the running rail, e.g. the third rail or a conductor rail in the ground.

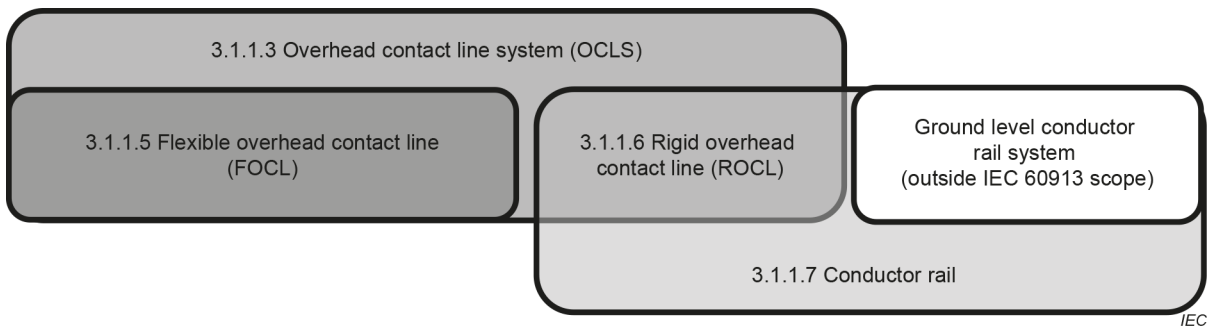

Figure 1 – Scope of contact line systems **2**

## 2 Normative references

The following documents are referred to in the text in such a way that some or all of their content constitutes requirements of this document. For dated references, only the edition cited applies. For undated references, the latest edition of the referenced document (including any amendments) applies.

~~NOTE Normative references are made to ISO and IEC standards. For some necessary references, ISO and IEC standards do not exist. In these cases, references are made to European Standards which are normative for Europe according to EN 50110. For non-European countries these references are only informative and listed in the bibliography.~~

~~IEC 60050-811, International Electrotechnical Vocabulary (IEV) – Chapter 811: Electric traction~~

~~IEC 60071 (all parts), Insulation co-ordination~~

~~IEC 60099 (all parts), Surge arresters~~

~~IEC 60099-1, Surge arresters – Part 1: Non-linear resistor type gapped surge arresters for a.c. systems~~

IEC 60099-4, Surge arresters – Part 4: Metal-oxide surge arresters without gaps for a.c. systems

IEC 60168, Tests on indoor and outdoor post insulators of ceramic material or glass for systems with nominal voltages greater than 1 000 V

IEC 60273, Characteristics of indoor and outdoor post insulators for systems with nominal voltages greater than 1 000 V

IEC 60305, Insulators for overhead lines with a nominal voltage above 1 000 V – Ceramic or glass insulator units for AC systems – Characteristics of insulator units of the cap and pin type

IEC 60383 (all parts), Insulators for overhead lines with nominal voltage above 1 000 V

IEC 60433, Insulators for overhead lines with a nominal voltage above 1 000 V – Ceramic insulators for AC systems – Characteristics of insulator units of the long rod type

~~IEC 60494 (all parts), Railway applications – Rolling stock – Pantographs – Characteristics and tests~~

IEC 60494-1, Railway applications – Rolling stock – Pantographs – Characteristics and tests – Part 1: Pantographs for main line vehicles

IEC 60494-2, Railway applications – Rolling stock – Pantographs – Characteristics and tests – Part 2: Pantographs for metros and light rail vehicles

IEC 60529, Degrees of protection provided by enclosures (IP Code)

IEC 60660, Insulators – Tests on indoor post insulators of organic material for systems with nominal voltages greater than 1 000 V up to but not including 300 kV

IEC 60672-1, Ceramic and glass insulating materials – Part 1: Definitions and classification

IEC 60672-2, Ceramic and glass insulating materials – Part 2: Methods of test

IEC 60672-3, Ceramic and glass-insulating materials – Part 3: Specifications for individual materials

IEC 60850, Railway applications – Supply voltages of traction systems

~~IEC 60889, Hard-drawn aluminium wire for overhead line conductors~~

IEC 60947-1, Low-voltage switchgear and controlgear – Part 1: General rules

IEC 61089, Round wire concentric lay overhead electrical stranded conductors

~~IEC 61109, Insulators for overhead lines – Composite suspension and tension insulators for a.c. systems with a nominal voltage greater than 1 000 V – Definitions, test methods and acceptance criteria~~

~~IEC 61232, Aluminium-clad steel wires for electrical purposes~~

IEC/TR TS 61245, Artificial pollution tests on high-voltage ceramic and glass insulators to be used on d.c. systems

IEC 61325, Insulators for overhead lines with a nominal voltage above 1 000 V – Ceramic or glass insulator units for d.c. systems – Definitions, test methods and acceptance criteria

IEC 61284:1997, Overhead lines – Requirements and tests for fittings

IEC 61773, Overhead lines – Testing of foundations for structures

~~IEC 61952, Insulators for overhead lines – Composite line post insulators for a.c. systems with a nominal voltage greater than 1 000 V – Definitions, test methods and acceptance criteria~~

~~IEC 61992 (all parts), Railway applications – Fixed installations – DC switchgear~~

IEC 61992-1, Railway applications – Fixed installations – DC switchgear – Part 1: General

IEC 61992-4, Railway applications – Fixed installations – DC switchgear – Part 4: Outdoor d.c. disconnectors, switch-disconnectors and earthing switches

~~IEC 61992-5, Railway applications – Fixed installations – DC switchgear – Part 5: Surge arresters and low-voltage limiters for specific use in d.c. systems~~

IEC 62128 (all parts), Railway applications – Fixed installations – Electrical safety, earthing and the return circuit

~~IEC 62128-1:2003, Railway applications – Fixed installations – Part 1: Protective provisions relating to electrical safety and earthing~~

~~IEC 62128-2:2003, Railway applications – Fixed installations – Part 2: Protective provisions against the effects of stray currents caused by d.c. traction systems~~

IEC 62236-2:2008, Railway applications – Electromagnetic compatibility – Part 2: Emission of the whole railway system to the outside world

~~IEC 62271-102, High voltage switchgear and controlgear – Part 102: Alternating current disconnectors and earthing switches~~

~~IEC 62271-103:2011, High voltage switchgear and controlgear – Part 103: Switches for rated voltages above 1 kV up to and including 52 kV~~

IEC 62313, Railway applications – Power supply and rolling stock – Technical criteria for the coordination between power supply (substation) and rolling stock

IEC 62486:2017, Railway applications – Current collection systems – Technical criteria for the interaction between pantograph and overhead contact line (to achieve free access)

~~IEC 62497 (all parts), Railway applications – Insulation coordination~~

IEC 62497-1:2010, *Railway applications – Insulation coordination – Part 1: Basic requirements – Clearances and creepage distances for all electrical and electronic equipment*  
IEC 62497-1:2010/AMD1:2013

IEC 62497-2, *Railway applications – Insulation coordination – Part 2: Overvoltages and related protection*

IEC 62498-2:2010, *Railway applications – Environmental conditions for equipment – Part 2: Fixed electrical installations*

~~IEC 62505 (all parts), Railway applications – Fixed installations – Particular requirements for a.c. switchgear~~

IEC 62505-2, *Railway applications – Fixed installations – Particular requirements for AC switchgear – Part 2: ~~Single-phase~~ Disconnectors, earthing switches and switches with  ~~$U_n$~~  nominal voltage above 1 kV*

IEC 62621, *Railway applications – Fixed installations – Electric traction – Special requirements for composite insulators used for overhead contact line systems*

IEC 62641: 2022, *Conductors for overhead lines – Aluminium and aluminium alloy wires for concentric lay stranded conductors*

IEC 62724, *Railway applications – Fixed installations – Electric traction – Insulating synthetic rope assemblies for support of overhead contact lines*

IEC 62846:2016, *Railway applications – Current collection systems – Requirements for and validation of measurements of the dynamic interaction between pantograph and overhead contact line*

IEC 62848 (all parts), *Railway applications – DC surge arresters and voltage limiting devices*

IEC 62917, *Railway applications – Fixed installations – Electric traction – Copper and copper alloy grooved contact wires*

IEC 63190, *Railway applications – Fixed installations – Electric traction – Copper and copper alloy catenary wires for overhead contact line systems*

IEC 63248: 2022, *Conductors for overhead lines – Coated or clad metallic wire for concentric lay stranded conductors*

IEC 63438, *Railway applications – Fixed installations – Protection principles for AC and DC electric traction power supply systems<sup>1</sup>*

IEC 63453, *Railway applications – Current collection systems – Validation of simulation of the dynamic interaction between pantograph and overhead contact line<sup>2</sup>*

ISO 630 (all parts), *Structural steels*

---

<sup>1</sup> Under preparation. Stage at the time of publication: IEC/AFDIS 63438:2023.

<sup>2</sup> Under preparation. Stage at the time of publication: IEC/CCDV 63453:2023.

ISO 898-1:2013, *Mechanical properties of fasteners made of carbon steel and alloy steel – Part 1: Bolts, screws and studs with specified property classes – Coarse thread and fine pitch thread*

ISO 898-2:2012, *Mechanical properties of fasteners made of carbon steel and alloy steel – Part 2: Nuts with specified property classes – Coarse thread and fine pitch thread*

ISO 1461:2022, *Hot dip galvanized coatings on fabricated iron and steel articles – Specifications and test methods*

ISO 2394, *General principles on reliability for structures*

ISO 2859 (all parts), *Sampling procedures for inspection by attributes*

~~ISO 3010:2001, *Basis for design of structures – Seismic actions on structures*~~

ISO 4354, *Wind actions on structures*

ISO 10721 (all parts), *Steel structures*

~~ISO/TR 11069:1995, *Aluminium structures – Material and design – Ultimate limit state under static loading*~~

~~ISO 14688-1, *Geotechnical investigation and testing – Identification and classification of soil – Part 1: Identification and description*~~

~~ISO 14688-2, *Geotechnical investigation and testing – Identification and classification of soil – Part 2: Principles for a classification*~~

~~ISO 14689-1, *Geotechnical investigation and testing – Identification and classification of rock – Part 1: Identification and description*~~

ISO 14713 (all parts), *Zinc coatings – Guidelines and recommendations for the protection against corrosion of iron and steel in structures*

~~ISO/TS 17892 (all parts), *Geotechnical investigation and testing – Laboratory testing of soil*~~

~~ISO 22475-1, *Geotechnical investigation and testing – Sampling methods and groundwater measurements – Part 1: Technical principles for execution*~~

~~ISO 22476-2, *Geotechnical investigation and testing – Field testing – Part 2: Dynamic probing*~~

~~ISO 22476-3, *Geotechnical investigation and testing – Field testing – Part 3: Standard penetration test*~~

~~ISO 23469:2005, *Bases for design of structures – Seismic actions for designing geotechnical works*~~



# INTERNATIONAL STANDARD



**Railway applications – Fixed installations – Electric traction overhead contact lines systems**

## CONTENTS

FOREWORD.....	9
1 Scope.....	11
2 Normative references .....	11
3 Terms, definitions, symbols and abbreviated terms.....	14
3.1 Terms and definition .....	14
3.1.1 Systems .....	14
3.1.2 Conductors .....	18
3.1.3 Return circuit.....	19
3.1.4 Electrical .....	20
3.1.5 Geometrical.....	21
3.1.6 Structures.....	23
3.1.7 Foundations.....	24
3.1.8 Current collectors .....	24
3.1.9 Current collection .....	25
3.1.10 Testing .....	25
3.1.11 Miscellaneous.....	26
3.2 Symbols.....	26
3.3 Abbreviated terms.....	29
4 Fundamental design data .....	29
4.1 General.....	29
4.2 Line characteristics.....	29
4.3 Electrical power system design .....	30
4.4 Vehicle characteristics .....	30
4.5 Current collectors .....	30
4.6 Environmental conditions .....	31
4.7 Design life.....	31
5 System requirements.....	31
5.1 Design of electrical system .....	31
5.1.1 General .....	31
5.1.2 Temperature rise in conductors .....	31
5.1.3 Clearances between live parts of contact lines and earth.....	33
5.1.4 Clearances between adjacent live AC contact lines of differing voltage phases.....	35
5.2 Design of overhead contact line for current collection systems.....	36
5.2.1 General .....	36
5.2.2 Elasticity and its variation .....	37
5.2.3 Vertical movement of contact point .....	37
5.2.4 Calculated wave propagation velocity .....	37
5.2.5 Quality of current collection .....	38
5.2.6 Fatigue of contact wire .....	40
5.3 Mechanical design of contact wire loads .....	40
5.3.1 Permissible tensile stress $\sigma_w$ .....	40
5.3.2 Maximum temperature $K_{temp}$ .....	40
5.3.3 Allowable wear $K_{wear}$ .....	41
5.3.4 Wind loads $K_{wind}$ .....	41
5.3.5 Ice loads $K_{ice}$ .....	41

5.3.6	Efficiency of tensioning devices $K_{\text{eff}}$ .....	41
5.3.7	Termination fittings $K_{\text{clamp}}$ .....	42
5.3.8	Joints $K_{\text{joint}}$ .....	42
5.4	Mechanical design of catenary wire loads .....	42
5.4.1	Permissible tensile loading $F_{\text{w}}$ .....	42
5.4.2	Maximum temperature $K_{\text{temp}}$ .....	42
5.4.3	Wind loads $K_{\text{wind}}$ .....	43
5.4.4	Ice loads $K_{\text{ice}}$ .....	43
5.4.5	Efficiency and accuracy of tensioning device $K_{\text{eff}}$ .....	44
5.4.6	Termination fittings $K_{\text{clamp}}$ .....	44
5.4.7	Additional vertical load $K_{\text{load}}$ .....	44
5.5	Mechanical design of other stranded conductors .....	44
5.6	Mechanical design of solid wires .....	44
5.7	Mechanical design of ropes of non-conducting materials.....	44
5.7.1	General .....	44
5.7.2	Permissible tensile loading $F_{\text{w}}$ .....	44
5.7.3	Wind loads $K_{\text{wind}}$ .....	45
5.7.4	Ice loads $K_{\text{ice}}$ .....	45
5.7.5	Termination clamps $K_{\text{clamp}}$ .....	45
5.7.6	Vertical loads $K_{\text{load}}$ .....	45
5.7.7	Minimum bending radius $K_{\text{radius}}$ .....	45
5.8	Suspension systems .....	45
5.9	Tensioning device for flexible overhead contact lines .....	46
5.10	Geometry of overhead equipment .....	46
5.10.1	Lateral deviation of contact wire .....	46
5.10.2	Uplift.....	47
5.10.3	Variation in contact wire height.....	47
5.10.4	Contact wire height.....	48
5.10.5	Tolerances of lateral contact wire position .....	50
5.10.6	Span length .....	50
5.11	Contact line arrangement above turnouts and crossings .....	50
5.12	Overlap arrangements .....	51
5.13	Specific requirements for overhead contact lines for trolleybus systems .....	51
5.13.1	General .....	51
5.13.2	Line characteristics.....	51
5.13.3	Vehicle characteristics.....	53
5.13.4	Current collector system .....	53
5.13.5	Static contact forces .....	53
5.13.6	Trolleybus in the vicinity of tramways.....	53
5.14	Tolerances and limits .....	54
6	Structures and foundations .....	55
6.1	Basis of design .....	55
6.1.1	General .....	55
6.1.2	Basic requirements .....	55
6.1.3	Design with regard to structural limits .....	56
6.1.4	Classification of actions .....	56

6.1.5	Reliability levels.....	57
6.1.6	Models for structural analysis and resistance.....	57
6.1.7	Design values and verification methods.....	57
6.1.8	Wall anchors.....	59
6.2	Actions on overhead contact lines.....	59
6.2.1	General.....	59
6.2.2	Permanent loads.....	60
6.2.3	Variable loads.....	60
6.2.4	Wind loads.....	60
6.2.5	Ice loads.....	64
6.2.6	Combined wind and ice loads.....	64
6.2.7	Temperature effects.....	65
6.2.8	Construction and maintenance loads.....	65
6.2.9	Accidental loads.....	65
6.2.10	Special actions.....	65
6.3	Types of structures and related load cases.....	66
6.3.1	Load cases and load combinations.....	66
6.3.2	Type of structures and application of load cases.....	67
6.3.3	Partial factors for actions.....	70
6.4	Design of cross-span supports and structures.....	71
6.4.1	Analysis of internal forces and moments.....	71
6.4.2	Analysis of resistance.....	71
6.4.3	Material partial factors.....	72
6.4.4	Verification of resistance.....	72
6.4.5	Verification of serviceability.....	72
6.4.6	Material for structures.....	72
6.4.7	Corrosion protection and finishes.....	73
6.5	Foundations.....	73
6.5.1	General.....	73
6.5.2	Design of foundations.....	73
6.5.3	Calculation of actions.....	74
6.5.4	Geotechnical design.....	74
6.5.5	Partial factors for foundations.....	77
6.5.6	Verification of stability.....	77
6.5.7	Calculation of displacements.....	78
6.5.8	Materials for foundations.....	78
6.5.9	Structural details.....	79
6.5.10	Protection against corrosion and weathering.....	79
6.5.11	Electrical design.....	80
6.5.12	Installation of foundations.....	80
7	Assembly and Component requirements.....	81
7.1	General.....	81
7.1.1	Design life.....	81
7.1.2	Component identification.....	81
7.1.3	Corrosion and erosion.....	81
7.2	Supporting assemblies.....	81
7.3	Contact wire.....	82
7.4	Other conductors and ropes.....	82
7.5	Tensioning devices.....	82

7.6	Mechanical midpoints.....	83
7.6.1	General .....	83
7.6.2	Catenary wire fixed points .....	83
7.6.3	Contact wire fixed points.....	83
7.7	Droppers.....	83
7.7.1	Mechanical requirements .....	83
7.7.2	Electrical requirements .....	84
7.8	Clamps and line fittings.....	84
7.8.1	Mechanical requirements .....	84
7.8.2	Electrical requirements .....	84
7.9	Electrical connectors.....	85
7.10	Insulators.....	85
7.10.1	General requirements .....	85
7.10.2	Mechanical requirements .....	85
7.10.3	Insulator surface.....	86
7.11	Sectioning devices .....	86
7.11.1	Definition .....	86
7.11.2	Mechanical requirements .....	86
7.11.3	Electrical requirements .....	86
7.12	Disconnectors and drives .....	86
7.13	Protection devices .....	87
7.13.1	Covers and obstacles .....	87
7.13.2	Surge protection and voltage limiting devices .....	87
7.14	Specific components for trolleybus systems .....	87
7.14.1	General .....	87
7.14.2	Turnouts and crossings .....	88
7.15	Automatic earthing and short-circuiting equipment .....	88
7.16	Monitoring devices .....	88
8	Testing .....	89
8.1	Testing of components and assemblies – General .....	89
8.2	Support assemblies .....	89
8.2.1	Type test .....	89
8.2.2	Sampling test.....	98
8.2.3	Routine test.....	100
8.3	Contact wires.....	100
8.4	Other conductors .....	100
8.5	Tensioning devices .....	100
8.5.1	Tests required .....	100
8.5.2	Type tests for tensioning devices with balance weights.....	101
8.5.3	Type tests for tensioning device without balance weight .....	102
8.6	Mechanical midpoints.....	102
8.7	Droppers.....	102
8.7.1	Tests required .....	102
8.7.2	Mechanical fatigue test.....	102
8.7.3	Mechanical tests.....	105
8.8	Clamps, splices and other fittings.....	105
8.9	Electrical connectors.....	105
8.9.1	General .....	105
8.9.2	Mechanical fatigue tests .....	106

8.10	Insulators	106
8.11	Sectioning devices	107
8.11.1	Type test	107
8.11.2	Field test	108
8.11.3	Sampling tests	108
8.11.4	Routine tests	108
8.12	Disconnectors and drives	108
8.13	Surge protection and voltage limiting devices	108
8.14	Specific components for trolleybus systems	108
8.15	System test	109
8.15.1	Demonstration of conformity	109
8.15.2	Acceptance tests	109
8.15.3	Commissioning tests	110
9	Minimum documentation	110
9.1	General	110
9.2	System specification	110
9.3	Basic design	110
9.4	Installation design	110
9.5	Installation and maintenance	111
Annex A (informative)	Structural details	112
Annex B (informative)	Information on wind load calculation	113
B.1	Peak velocity pressure calculation	113
B.2	Drag factors $C_{str}$	114
Annex C (informative)	Recommendations for ultimate limit state (ULS) design	115
C.1	General	115
C.2	Material partial factors for structural calculations	115
C.3	Design limits for pre-stresses concrete poles	115
C.4	Partial factors for foundations	116
Annex D (informative)	Geotechnical soil investigation and soil characteristics	117
Annex E (informative)	Overhead contact line for electric vehicles with pantographs on electrified roads	119
E.1	General OCL properties and road characteristics	119
E.2	Electrical properties of the OCL	119
E.3	Capacity and service life of the OCL system	120
E.4	OCL properties	120
E.4.1	OCL mechanical properties, horizontal and vertical dimensions	120
E.4.2	Design of begin and end of OCLS	122
E.4.3	Uplift and dynamic properties of the OCL	123
E.5	Contact forces	123
E.6	ERS clearance requirements	124
E.6.1	General	124
E.6.2	Contact wire clamps	126
E.6.3	Miscellaneous structure gauges and clearance requirements	126
E.6.4	Structure gauge width – Lateral clearance requirements	127
E.6.5	Clearance under bridges or height-limiting structures	127
Annex F (informative)	Information on uniformity of elasticity of OCL within a span length	128
Annex G (informative)	Seismic actions for OCS poles on viaducts	129

Annex H (normative) Special national conditions.....	130
Bibliography.....	133
Figure 1 – Scope of contact line systems .....	11
Figure 2 – Static electrical clearance in air between live parts of an insulator and earthed equipment.....	35
Figure 3 – Relationship between contact wire heights and pantograph operating position.....	49
Figure 4 – Position of return wire in relation to right-of-way.....	52
Figure 5 – Wind action on lattice steel structures .....	63
Figure 6 – Definition of drag factors for double channel pole.....	64
Figure 7 – Description of dimensions and minimum conductor lengths .....	96
Figure 8 – Potential measuring points .....	97
Figure 9 – Potential measuring points at a T-type infeed terminal .....	98
Figure 10 – Example of a tensioning device measurement test .....	101
Figure 11 – Examples of a dropper test cycle.....	104
Figure 12 – Example of a dropper tension test assembly .....	105
Figure 13 – Example of a test cycle for an electrical connection.....	106
Figure E.1 – Overlap span (plan view, exemplary design for anchoring, representation without electrical connections) .....	122
Figure E.2 – Defined points along the OCL (side view, idealized).....	122
Figure E.3 – Clearance gauge overview.....	124
Figure E.4 – Clearance gauge detail .....	125
Figure G.1 – Simulation method for evaluation for the safety of poles against earthquakes.....	129
Table 1 – Temperature limits for material mechanical properties.....	32
Table 2 – Typical electrical clearances.....	34
Table 3 – Typical clearances between adjacent live AC contact line systems of differing voltage phase.....	36
Table 4 – Contact force limits .....	39
Table 5 – Factor $K_{temp}$ for contact wires .....	40
Table 6 – Factor $K_{wind}$ for contact wires.....	41
Table 7 – Factor $K_{ice}$ for contact wires .....	41
Table 8 – Factor $K_{temp}$ for stranded conductors .....	43
Table 9 – Factor $K_{wind}$ for stranded conductors .....	43
Table 10 – Factor $K_{ice}$ for stranded conductors .....	43
Table 11 – Factor $K_{radius}$ for ropes of non-conducting materials .....	45
Table 12 – Recommended maximum contact wire gradients for flexible contact lines.....	47
Table 13 – Important parameters to assist in the definition of tolerances and limits.....	54
Table 14 – Parameters for wind load calculation .....	61
Table 15 – Load cases to be considered for each type of structures .....	69
Table 16 – Partial factors for actions to be considered .....	71

Table 17 – Tightening torques $M_t$ for regularly used bolts .....	90
Table 18 – Examples of bolt connections .....	91
Table 19 – Assignment of the strength of bolt and nut.....	91
Table 20 – Conversion factor for tightening torques .....	92
Table 21 – Minimum conductor lengths .....	96
Table A.1 – Recommended dimensions of connections and edge distances of jointing components .....	112
Table B.1 – Recommended values for gust response factor $G_q$ .....	113
Table B.2 – Recommended values for terrain factor $G_t$ .....	113
Table B.3 – Recommended values for factor $C_{str}$ for different pole types.....	114
Table C.1 – Recommended values for partial factors $\gamma_M$ for steel structures .....	115
Table C.2 – Recommended values for partial factors $\gamma_M$ for concrete structures .....	115
Table C.3 – Recommended values for partial factors $\gamma_M$ for foundations .....	116
Table D.1 – Geotechnical characteristic parameters of some standard soils according to EN 50341-1:2012, Table M.2 .....	118
Table E.1 – Standard contact wire specifications .....	120
Table E.2 – Contact wire vertical position parameters, all values measured perpendicular to the idealized top of the road surface .....	121
Table E.3 – Contact wire horizontal position parameters .....	121
Table E.4 – Defined points along the OCL (side view).....	123
Table E.5 – Contact forces pantograph – OCL .....	123
Table E.6 – Clearance gauge overview description .....	125
Table E.7 – Pantograph clearance definitions .....	126
Table F.1 – Uniformity $u$ of elasticity .....	128
Table H.1 – Typical tolerances of overhead contact line system.....	130



## INTERNATIONAL ELECTROTECHNICAL COMMISSION

---

**RAILWAY APPLICATIONS – FIXED INSTALLATIONS –  
ELECTRIC TRACTION OVERHEAD CONTACT LINE SYSTEMS****FOREWORD**

- 1) The International Electrotechnical Commission (IEC) is a worldwide organization for standardization comprising all national electrotechnical committees (IEC National Committees). The object of IEC is to promote international co-operation on all questions concerning standardization in the electrical and electronic fields. To this end and in addition to other activities, IEC publishes International Standards, Technical Specifications, Technical Reports, Publicly Available Specifications (PAS) and Guides (hereafter referred to as “IEC Publication(s)”). Their preparation is entrusted to technical committees; any IEC National Committee interested in the subject dealt with may participate in this preparatory work. International, governmental and non-governmental organizations liaising with the IEC also participate in this preparation. IEC collaborates closely with the International Organization for Standardization (ISO) in accordance with conditions determined by agreement between the two organizations.
- 2) The formal decisions or agreements of IEC on technical matters express, as nearly as possible, an international consensus of opinion on the relevant subjects since each technical committee has representation from all interested IEC National Committees.
- 3) IEC Publications have the form of recommendations for international use and are accepted by IEC National Committees in that sense. While all reasonable efforts are made to ensure that the technical content of IEC Publications is accurate, IEC cannot be held responsible for the way in which they are used or for any misinterpretation by any end user.
- 4) In order to promote international uniformity, IEC National Committees undertake to apply IEC Publications transparently to the maximum extent possible in their national and regional publications. Any divergence between any IEC Publication and the corresponding national or regional publication shall be clearly indicated in the latter.
- 5) IEC itself does not provide any attestation of conformity. Independent certification bodies provide conformity assessment services and, in some areas, access to IEC marks of conformity. IEC is not responsible for any services carried out by independent certification bodies.
- 6) All users should ensure that they have the latest edition of this publication.
- 7) No liability shall attach to IEC or its directors, employees, servants or agents including individual experts and members of its technical committees and IEC National Committees for any personal injury, property damage or other damage of any nature whatsoever, whether direct or indirect, or for costs (including legal fees) and expenses arising out of the publication, use of, or reliance upon, this IEC Publication or any other IEC Publications.
- 8) Attention is drawn to the Normative references cited in this publication. Use of the referenced publications is indispensable for the correct application of this publication.
- 9) IEC draws attention to the possibility that the implementation of this document may involve the use of (a) patent(s). IEC takes no position concerning the evidence, validity or applicability of any claimed patent rights in respect thereof. As of the date of publication of this document, IEC had not received notice of (a) patent(s), which may be required to implement this document. However, implementers are cautioned that this may not represent the latest information, which may be obtained from the patent database available at <https://patents.iec.ch>. IEC shall not be held responsible for identifying any or all such patent rights.

IEC 60913 has been prepared by IEC technical committee 9: Electrical equipment and systems for railways. It is an International Standard.

This third edition cancels and replaces the second edition published in 2013. This edition constitutes a technical revision.

The European standard EN 50119 has served as a basis for the elaboration of this document.

This edition includes the following significant technical changes with respect to the previous edition:

- a) title modified;
- b) requirements for urban rail systems are included;
- c) requirements for rigid overhead contact line (ROCL) are included;
- d) additional definitions for new terms are included (Clause 3);

- e) clearances and geometry of overhead contact line are improved (Clause 5);
- f) urban aspects are added, for example wall anchors (Clause 6);
- g) requirements for monitoring devices, automatic earthing and short-circuiting equipment are included (Clause 7);
- h) requirements for overhead contact line for electric vehicles with pantograph on electrified roads are added (Annex E)
- i) improvements on the basis of EN 50119:2020 and the questionnaire 9/2619A/Q

The text of this International Standard is based on the following documents:

Draft	Report on voting
9/3031/FDIS	9/3052/RVD

Full information on the voting for its approval can be found in the report on voting indicated in the above table.

The language used for the development of this International Standard is English.

This document was drafted in accordance with ISO/IEC Directives, Part 2, and developed in accordance with ISO/IEC Directives, Part 1 and ISO/IEC Directives, IEC Supplement, available at [www.iec.ch/members\\_experts/refdocs](http://www.iec.ch/members_experts/refdocs). The main document types developed by IEC are described in greater detail at [www.iec.ch/publications](http://www.iec.ch/publications).

The reader's attention is drawn to the fact that Annex H lists all of the "in-some-country" clauses on differing practices of a less permanent nature relating to the subject of this document.

The committee has decided that the contents of this document will remain unchanged until the stability date indicated on the IEC website under [webstore.iec.ch](http://webstore.iec.ch) in the data related to the specific document. At this date, the document will be

- reconfirmed,
- withdrawn, or
- revised.

**IMPORTANT – The "colour inside" logo on the cover page of this document indicates that it contains colours which are considered to be useful for the correct understanding of its contents. Users should therefore print this document using a colour printer.**

## RAILWAY APPLICATIONS – FIXED INSTALLATIONS – ELECTRIC TRACTION OVERHEAD CONTACT LINE SYSTEMS

### 1 Scope

This document specifies the requirements and tests for the design of overhead contact line systems, requirements for structures and their structural calculations and verifications as well as the requirements and tests for the design of assemblies and individual parts.

This document is applicable to electric traction overhead contact line systems in heavy railways, light railways, for trolley bus lines, electric road systems (Annex E) and industrial railways of public and private operators. This document is applicable to new installations of overhead contact line systems and for the complete renewal of existing overhead contact line systems.

This document does not apply to ground level conductor rail systems (see Figure 1).

NOTE Ground level conductor rail means conductor rails located adjacent to the running rail, e.g. the third rail or a conductor rail in the ground.

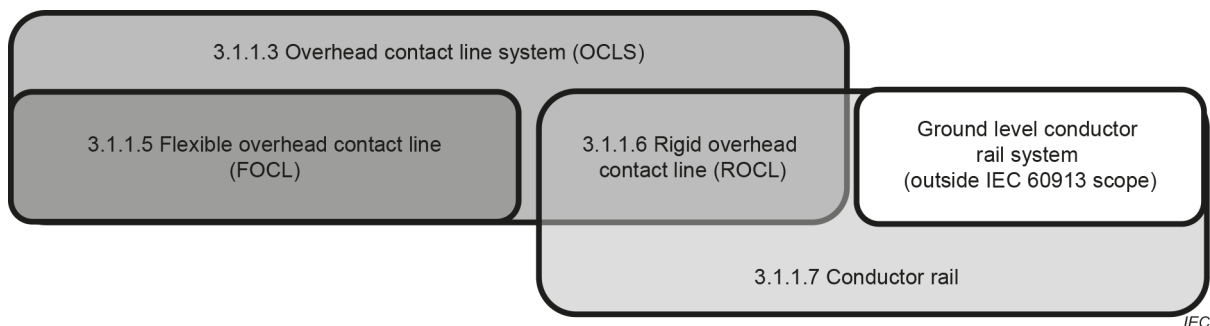

**Figure 1 – Scope of contact line systems**

### 2 Normative references

The following documents are referred to in the text in such a way that some or all of their content constitutes requirements of this document. For dated references, only the edition cited applies. For undated references, the latest edition of the referenced document (including any amendments) applies.

IEC 60099-4, *Surge arresters – Part 4: Metal-oxide surge arresters without gaps for a.c. systems*

IEC 60168, *Tests on indoor and outdoor post insulators of ceramic material or glass for systems with nominal voltages greater than 1 000 V*

IEC 60273, *Characteristics of indoor and outdoor post insulators for systems with nominal voltages greater than 1 000 V*

IEC 60305, *Insulators for overhead lines with a nominal voltage above 1 000 V – Ceramic or glass insulator units for AC systems – Characteristics of insulator units of the cap and pin type*

IEC 60383 (all parts), *Insulators for overhead lines with nominal voltage above 1 000 V*

IEC 60433, *Insulators for overhead lines with a nominal voltage above 1 000 V – Ceramic insulators for AC systems – Characteristics of insulator units of the long rod type*

IEC 60494-1, *Railway applications – Rolling stock – Pantographs – Characteristics and tests – Part 1: Pantographs for main line vehicles*

IEC 60494-2, *Railway applications – Rolling stock – Pantographs – Characteristics and tests – Part 2: Pantographs for metros and light rail vehicles*

IEC 60529, *Degrees of protection provided by enclosures (IP Code)*

IEC 60660, *Insulators – Tests on indoor post insulators of organic material for systems with nominal voltages greater than 1 000 V up to but not including 300 kV*

IEC 60672-1, *Ceramic and glass insulating materials – Part 1: Definitions and classification*

IEC 60672-2, *Ceramic and glass insulating materials – Part 2: Methods of test*

IEC 60672-3, *Ceramic and glass-insulating materials – Part 3: Specifications for individual materials*

IEC 60850, *Railway applications – Supply voltages of traction systems*

IEC 60947-1, *Low-voltage switchgear and controlgear – Part 1: General rules*

IEC 61089, *Round wire concentric lay overhead electrical stranded conductors*

IEC TS 61245, *Artificial pollution tests on high-voltage ceramic and glass insulators to be used on d.c. systems*

IEC 61325, *Insulators for overhead lines with a nominal voltage above 1 000 V – Ceramic or glass insulator units for d.c. systems – Definitions, test methods and acceptance criteria*

IEC 61284:1997, *Overhead lines – Requirements and tests for fittings*

IEC 61773, *Overhead lines – Testing of foundations for structures*

IEC 61992-1, *Railway applications – Fixed installations – DC switchgear – Part 1: General*

IEC 61992-4, *Railway applications – Fixed installations – DC switchgear – Part 4: Outdoor d.c. disconnectors, switch-disconnectors and earthing switches*

IEC 62128 (all parts), *Railway applications – Fixed installations – Electrical safety, earthing and the return circuit*

IEC 62236-2, *Railway applications – Electromagnetic compatibility – Part 2: Emission of the whole railway system to the outside world*

IEC 62313, *Railway applications – Power supply and rolling stock – Technical criteria for the coordination between power supply (substation) and rolling stock*

IEC 62486:2017, *Railway applications – Current collection systems – Technical criteria for the interaction between pantograph and overhead contact line (to achieve free access)*

IEC 62497-1:2010, *Railway applications – Insulation coordination – Part 1: Basic requirements – Clearances and creepage distances for all electrical and electronic equipment*  
IEC 62497-1:2010/AMD1:2013

IEC 62497-2, *Railway applications – Insulation coordination – Part 2: Overvoltages and related protection*

IEC 62498-2:2010, *Railway applications – Environmental conditions for equipment – Part 2: Fixed electrical installations*

IEC 62505-2, *Railway applications – Fixed installations – Particular requirements for AC switchgear – Part 2: Disconnectors, earthing switches and switches with nominal voltage above 1 kV*

IEC 62621, *Railway applications – Fixed installations – Electric traction – Special requirements for composite insulators used for overhead contact line systems*

IEC 62641: 2022, *Conductors for overhead lines – Aluminium and aluminium alloy wires for concentric lay stranded conductors*

IEC 62724, *Railway applications – Fixed installations – Electric traction – Insulating synthetic rope assemblies for support of overhead contact lines*

IEC 62846:2016, *Railway applications – Current collection systems – Requirements for and validation of measurements of the dynamic interaction between pantograph and overhead contact line*

IEC 62848 (all parts), *Railway applications – DC surge arresters and voltage limiting devices*

IEC 62917, *Railway applications – Fixed installations – Electric traction – Copper and copper alloy grooved contact wires*

IEC 63190, *Railway applications – Fixed installations – Electric traction – Copper and copper alloy catenary wires for overhead contact line systems*

IEC 63248: 2022, *Conductors for overhead lines – Coated or clad metallic wire for concentric lay stranded conductors*

IEC 63438, *Railway applications – Fixed installations – Protection principles for AC and DC electric traction power supply systems<sup>1</sup>*

IEC 63453, *Railway applications – Current collection systems – Validation of simulation of the dynamic interaction between pantograph and overhead contact line<sup>2</sup>*

ISO 630 (all parts), *Structural steels*

ISO 898-1:2013, *Mechanical properties of fasteners made of carbon steel and alloy steel – Part 1: Bolts, screws and studs with specified property classes – Coarse thread and fine pitch thread*

---

<sup>1</sup> Under preparation. Stage at the time of publication: IEC/AFDIS 63438:2023.

<sup>2</sup> Under preparation. Stage at the time of publication: IEC/CCDV 63453:2023.

ISO 898-2:2012, *Mechanical properties of fasteners made of carbon steel and alloy steel – Part 2: Nuts with specified property classes – Coarse thread and fine pitch thread*

ISO 1461:2022, *Hot dip galvanized coatings on fabricated iron and steel articles – Specifications and test methods*

ISO 2394, *General principles on reliability for structures*

ISO 2859 (all parts), *Sampling procedures for inspection by attributes*

ISO 4354, *Wind actions on structures*

ISO 10721 (all parts), *Steel structures*

ISO 14713 (all parts), *Zinc coatings – Guidelines and recommendations for the protection against corrosion of iron and steel in structures*